Masters Theses

Student Theses and Dissertations

Fall 2009

Screw connections subject to tension pull-out and shear forces

Ryan M. Francka

Follow this and additional works at: https://scholarsmine.mst.edu/masters_theses



Part of the [Civil Engineering Commons](#)

Department:

Recommended Citation

Francka, Ryan M., "Screw connections subject to tension pull-out and shear forces" (2009). *Masters Theses*. 4720.

https://scholarsmine.mst.edu/masters_theses/4720

This thesis is brought to you by Scholars' Mine, a service of the Missouri S&T Library and Learning Resources. This work is protected by U. S. Copyright Law. Unauthorized use including reproduction for redistribution requires the permission of the copyright holder. For more information, please contact scholarsmine@mst.edu.

SCREW CONNECTIONS SUBJECT
TO TENSION PULL-OUT AND SHEAR FORCES

by

RYAN MICHAEL FRANCKA

A THESIS

Presented to the Faculty of the Graduate School of the
MISSOURI UNIVERSITY OF SCIENCE AND TECHNOLOGY

In Partial Fulfillment of the Requirements for the Degree

MASTER OF SCIENCE IN CIVIL ENGINEERING

2009

Approved by

Dr. Roger A. LaBoube, Advisor
Dr. Ralph E. Flori
Dr. Wei-Wen Yu

ABSTRACT

Currently, the behavior of screw connections subject to combined tension pull-out and shear forces is not well understood. An experimental study was conducted at Missouri University of Science and Technology to better understand the relationship or interaction between these forces. The test program evaluated four parameters that may influence the behavior of pure tension and pure shear in screw connections: the thickness of the sheet not in contact with the screw head, the ultimate strength of the steel, the ductility of the steel, and the screw diameter. This investigation extends the application of the pure pull-out and pure shear equations in the *2007 North American Specification for the Design of Cold-Formed Steel Structural Members* produced by the American Iron and Steel Institute. Based on the behavior observed and analysis of the test data, this work formulated new design recommendations for use in calculating the design capacity of screw connections subject to this potential limit state.

ACKNOWLEDGMENTS

First, I would like to offer my thanks and appreciation to my advisor, Dr. Roger A. LaBoube. Not only did Dr. LaBoube guide me during my graduate program, but his dedication and enthusiasm during this study also created for me an enjoyable learning and work environment. I would also like to thank my committee members, Dr. Wei-Wen Yu and Dr. Ralph E. Flori, for all their valued input.

I would like to take this opportunity, also, to thank those who contributed financially to this study: the American Iron and Steel Institute; the Civil, Architectural, and Environmental Engineering Department at Missouri S&T; the Chancellor's Fellowship extended by Missouri S&T; and Dr. Wei-Wen Yu for the Wei-Wen Yu Graduate Fellowship. Their contributions are greatly appreciated and will not be forgotten.

I would also like to thank Michael Wolfe for his help. His dedication and hard work during the experimental testing phase of the study was very much valued.

Finally, I would like to thank those who have been there for me thus far in my life. My parents, Kenny and Kathy, provided me with my ideals and work ethic and taught me responsibility. For all this and so much more, I am extremely grateful. My wife, Tanzeena, has supported me with her encouragement, love, and understanding during graduate school. I could not ask for a better person to be married to, and I love her very much. To all my friends and other family members who have always believed in me, I am also exceedingly thankful.

TABLE OF CONTENTS

	Page
ABSTRACT	iii
ACKNOWLEDGMENTS	iv
LIST OF FIGURES	vii
LIST OF TABLES	viii
SECTION	
1. INTRODUCTION	1
1.1. GENERAL	1
1.2. APPLICATION	2
2. LITERATURE REVIEW	3
2.1. GENERAL	3
2.2. PREVIOUS RESEARCH	3
2.2.1. Pekoz	3
2.2.1.1. Design for pure shear	3
2.2.1.2. Design for pure tension	4
2.2.2. Ellifritt and Burnette	6
2.2.3. Zwick and LaBoube	6
2.2.4. American Iron and Steel Institute	8
2.2.4.1 Pure shear	9
2.2.4.2 Pure tension pull-out	10
2.2.4.3 Pure tension pull-over	10
2.2.4.4 Combined pull-over and shear	11
2.2.4.5 Ductility	13
3. EXPERIMENTAL INVESTIGATION	14
3.1. INTRODUCTION	14
3.2. SCOPE OF INVESTIGATION	14
3.2.1. Material Properties	14
3.2.2. Test Variables	15
3.3. TEST SPECIMEN AND TEST FIXTURE	17

3.3.1. Test Specimen: Parameters	17
3.3.2. Test Specimen: Fabrication	17
3.3.3. Test Fixture.....	19
3.3.4. Test Setup.....	21
3.3.5. Test Procedure.....	21
3.4. TEST RESULTS.....	25
3.4.1. Normal-Ductility Specimens.....	26
3.4.2. Low-Ductility Specimens.....	28
4. DATA ANALYSIS	29
4.1. INTRODUCTION	29
4.2. DATA ANALYSIS USING AISI EQUATIONS.....	29
4.2.1. Data for Analysis.....	29
4.2.2. Evaluating Screw Diameter.....	29
4.2.3. Shear versus Pull-out.....	31
4.3. DEVELOPMENT OF INTERACTION EQUATION	32
4.3.1. Tri-Linear Interaction Equation.....	32
4.3.2. Nonlinear Interaction Equation	34
5. SUMMARY AND DESIGN RECOMMENDATIONS	35
5.1. SUMMARY	35
5.2. DESIGN RECOMMENDATIONS	35
6. RECOMMENDATIONS FOR FUTURE RESEARCH	38
APPENDICES	
A. RESULTS OF TEST DATA.....	39
B. ANALYSIS OF TEST DATA	42
C. TRI-LINEAR EQUATION CORRELATION.....	45
D. NONLINEAR EQUATION CORRELATION	48
BIBLIOGRAPHY	52
VITA	53

LIST OF FIGURES

Figure	Page
1.1 Screw Connections Potentially Subjected to Pull-out and Shear Forces	2
3.1 Self-Drilling Screws.....	16
3.2 Angles of Rotation	16
3.3 Test Specimen Nominal Dimensions.....	17
3.4 Typical Test Specimen.....	18
3.5 Normal- and Low-Ductility Flat Sheets.....	19
3.6 Upper Fixture: Welded T-Sections 15°, 30°, and 60°	20
3.7 Lower Fixture: Rotating Arm	20
3.8 Modification Plate.....	21
3.9 MTS 880 Material Test System	22
3.10 Flat Sheet with Edge Stiffeners.....	22
3.11 Comparison of Stiffened versus Un-stiffened Failure Modes	24
3.12 Load versus Deflection of 30° Test Specimens	24
3.13 Example Load versus Deformation Curve.....	26
3.14 Typical Normal-Ductility Flat Sheet after Testing	27
3.15 Comparison of Normal- and Low-Ductility Flat Sheets.....	27
3.16 Typical Low-Ductility Flat Sheet after Testing.....	28
4.1 Evaluation of Screw Size at 30° – Normal Ductility	30
4.2 Evaluation of Screw Size at 30° – Low Ductility.....	31
4.3 Pull-out and Shear Interaction using AISI Equations	32
4.4 Tri-Linear Equation Interaction Relationship.....	33
4.5 Nonlinear Equation Interaction Relationship.....	34

LIST OF TABLES

Table	Page
3.1 Material Properties.....	15
3.2 Comparison of Stiffened versus Un-stiffened Test Specimens	23
3.3 Comparison of all Stiffened versus Un-stiffened Specimens at 15°	25

1. INTRODUCTION

1.1. GENERAL

In the 1940s, cold-formed steel started becoming popular in the United States for use in structural members. Compared to other materials such as timber and concrete, cold-formed steel has many advantages. It is light-weight, recyclable, termite-proof, and easy to erect and fabricate; it also has a high strength-to-weight ratio (Yu, 2000).

Screws are a practical and economical means to connect cold-formed steel structural members. They provide a rapid and effective way of connecting members subject to tension, shear, or combined tension and shear forces. For example, common construction methods often use cross bracing between joists to carry lateral loads. This bracing could be subject to simultaneous tension and shear forces.

In 1946, the American Iron and Steel Institute (AISI) began leading the building industry with the release of its first edition of the *Specification for the Design of Light Gage Steel Structural Members* (AISI, 1946). The AISI has since updated its specification many times to include new and safer design methods. The most recent edition, the *North American Specification for the Design of Cold-Formed Steel Structural Members* (specification), was released in 2007. Since 2001, the specification has been approved by the Canadian Standards Association for use in Canada and endorsed by CANACERO for use in Mexico.

Currently, the specification includes provisions that assess the design strength of a screw connection subject to pure tension, pure shear, and combined pull-over and shear forces. Additional guidance is required to determine the design capacity when screw connections are subject to both combined pull-out and shear forces.

1.2. APPLICATION

When using screws in cold-formed steel connections subject to combined tension and shear forces, if the bottom sheet (i.e., the sheet not in contact with the screw head) is thinner than the top sheet, tension pull-out and shear may occur.

Combined pull-out and shear occurs in many situations, such as connecting purlins to a spandrel beam using clip connectors or the connection of lateral bracing for wall studs. Figure 1.1 shows two examples of situations in which this limit state might occur.

The 2007 edition of the specification does not currently include provisions permitting consideration of the limit state of combined pull-out and shear. The lack of these provisions leaves engineers to rely solely on experience and judgment, which may result in either under-designed (unsafe) or over-designed (uneconomical) screw connections.

This study provides much-needed data that allows the formulation of a design methodology that provides engineers with a safe means to design screw connections subject to this limit state.



Figure 1.1 Screw Connections Potentially Subject to Pull-out and Shear Forces

2. LITERATURE REVIEW

2.1. GENERAL

Several research studies provide a foundation for this work. These have investigated pure tension pull-out and pure shear forces individually in screw connections. They have also reviewed combined pull-over and shear loading, thus establishing a basis for the interaction relationship of tension and shear in screw connections. They have not, however, considered the limit state of combined pull-out and shear forces in screw connections.

2.2. PREVIOUS RESEARCH

2.2.1. Pekoz. Working at Cornell University, Pekoz evaluated over 3500 tests from the United States, Canada, Sweden, Britain, and the Netherlands (Pekoz, 1990). The equations established by the European Convention for Constructional Steelwork (ECCS) took into consideration numerous parameters such as screw diameter, yield stress, and thickness of the connecting sheets. Using these equations as a basis for his analysis, Pekoz made various modifications.

2.2.1.1. Design for pure shear. Pekoz's study concluded that the design equations included among the ECCS recommendations were adequate for the design of pure shear, but could be modified to use ultimate tensile strength, F_u , instead of yield stress, F_y . This modification provides better agreement between observed and calculated results (Pekoz, 1990). Although these equations are based on empirical data, the modifications also provide uniformity with connection design in the United States. Tensile strength is typically used for connection design equations. With the

recommended modifications, the design equations for shear strength, P_{ns} , are given by Equations 2-1 through 2-3:

for $t_2/t_1 \leq 1.0$, the smaller of

$$P_{ns} = 4.2(t_1^3 d)^{1/2} F_u \quad \text{and} \quad (2-1)$$

$$P_{ns} = 2.7t_1 d F_u \quad (2-2)$$

for $t_2/t_1 \geq 2.5$

$$P_{ns} = 2.7t_1 d F_u \quad (2-3)$$

for $1.0 < t_2/t_1 < 2.5$, P_{ns} is determined by linear interpolation

where:

t_1 = thickness of the sheet in contact with the screw head

t_2 = thickness of the sheet not in contact with the screw head

d = nominal screw diameter

F_u = ultimate tensile strength

Pekoz's equations for pure shear were accepted by the AISI for the 1996 edition of the *Cold-Formed Steel Design Manual* and were retained in the 2007 edition of the specification.

2.2.1.2. Design for pure tension. As in the case of pure shear, Pekoz checked many tests against the ECCS recommendations. Although the existing equations correlated satisfactorily with the data, Pekoz concluded that using ultimate tensile strength, F_u , enhanced the correlation (Pekoz, 1990). For pull-out failure, he proposed the following design equation:

$$P_{not} = 0.85t_c d F_u \quad (2-4)$$

where:

t_c = lesser of depth of penetration or thickness, t_2

For the case of pull-over, the ECCS recommendations included two equations. One did not consider washer diameter as a variable (Equation 2-5), while another did (Equation 2-6). These equations were yet again adjusted to consider ultimate tensile strength and to use Customary units:

$$P_{nov} = 0.77td F_u \quad (2-5)$$

$$P_{nov} = 1.5td_w F_u \quad (2-6)$$

where:

t = thickness of the material

d_w = the larger of the diameter of the washer or the screw head, limited to $\frac{1}{2}$ in.

The AISI selected Equation 2-4 for pull-out and Equation 2-6 for pull-over. They accepted Pekoz's equations for pure tension for inclusion in the 1996 edition of the specification and they were retained in the 2007 edition. For both pure shear and pure tension, Pekoz also computed a resistance factor, ϕ , for Load and Resistance Factor Design (LRFD) and a safety factor, Ω , for Allowable Strength Design (ASD). Values of 0.5 and 3.0, respectively, appeared to be reasonable (Pekoz, 1990).

2.2.2. Ellifritt and Burnette. Research conducted by Ellifritt and Burnette simulated pull-over of screw connections in actual field conditions. When a roof panel is subject to an uplift force, the panel acts like a continuous beam, inducing forces that are not the same as a basic pull-over test (Ellifritt, 1990). Fourteen static suction tests were performed to evaluate pull-over of sheathing subject to suction loads. As a secondary objective, fifteen dynamic tests were carried out to evaluate fatigue loading similar to those imposed on older buildings. Thirteen standard pull-over tests were also performed as a baseline for comparison of the static and dynamic test results.

Ellifritt and Burnette concluded that the configurations of their static test were a better predictor of actual pull-over strength in a real building application. The results of the standard pull-over tests were reduced by a factor of approximately 0.4 for the material and configurations they tested (Ellifritt, 1990). This reduction factor is only valid for the static test setup Ellifritt and Burnette used. If the test setup was varied using different material and configurations (e.g. girt spacing, etc.), the results could vary.

Although the results of the dynamic tests were consistent, more tests were needed to draw firm conclusions. Ellifritt and Burnette showed that actual conditions could influence and reduce the capacity of screw connections calculated by design equations.

2.2.3. Zwick and LaBoube. Zwick and LaBoube sought to derive a design equation that considered screw connections when exposed to combined tension and shear forces, specifically tension pull-over (Zwick, 2006). They reviewed and analyzed the tests performed by Luttrell (1999) at the University of West Virginia.

Luttrell performed a total of 61 tests. Each test varied the controlling parameters: screw size, washer size, and sheet thickness. The angle, at which the force was applied,

was varied to induce several combinations of pull-over and shear. The existing AISI equations provided a basis for the relationship (or interaction) between the pull-over and shear forces.

Zwick and LaBoube used the nominal strength equations for pure shear (Equations 2-10 through 2-14) and pure pull-over (Equation 2-16) from the 1996 *Specification for the Design of Cold-Formed Steel Structural Members* to normalize the experimental pull-over and shear strength values by creating T/T_n and Q/Q_n ratios. They then used these ratios to create Equation 2-7 based on a best fit using regression analysis. Their analysis relied on the actual washer or screw size, d_w :

$$Q/Q_n = 0.5041(T/T_n)^{-0.4389} \quad (2-7)$$

where:

Q = test shear strength

$Q_n = 2.7tdF_u$

Q_n = nominal shear strength

T = test tensile strength

$T_n = 1.5td_wF_u$

T_n = nominal tensile strength

Using the existing limitations of the AISI specification, they limited d_w to ½ in. or less. Based on a best-fit regression analysis with this limitation, they derived Equation 2-8 much as they had Equation 2-7:

$$Q/Q_n = 0.517(T/T_n)^{-0.5317} \quad (2-8)$$

Following the same AISI limitations on d_w , they derived another equation similar to Equation 2-8 but based on a linear relationship rather than a best-fit regression analysis (2006). After simplifying and rewriting Equation 2-9 as the equation for calculating the strength of combined pull-over and shear forces, AISI adopted it for the 2007 specification:

$$Q/Q_n = 1.106 - 0.706(T/T_n) \quad (2-9)$$

Finally, based on statistical analysis safety factors for LRFD, ASD, and Limit State Design (LSD), were calculated. For Equation 2-9, the following limitations are applicable:

$$0.0285 \text{ in.} \leq t \leq 0.0445 \text{ in.}$$

No. 12 and No. 14 self-drilling screw with or without washers

$$d_w \leq 0.75 \text{ in.}$$

$$62 \text{ si} \leq F_u \leq 70.7 \text{ ksi}$$

2.2.4. American Iron and Steel Institute. AISI periodically updates the specification. Since 1996, this specification, (referred to as the *Specification for the Design of Cold-Formed Steel Structural Members prior to 2001*), has provided design methods for screw connections for cold-formed steel structural members. The provisions for pure shear and pure tension forces are based on Pekoz's work (1990) as reviewed in Section 2.2.1. The specification also provides provisions for screw connections subject to combined pull-over and shear forces based on the work of Zwick and LaBoube (2006) as reviewed in Section 2.2.3. The provisions for pure shear, pure tension, and combined pull-over and shear forces were clarified by AISI as the organization deemed necessary.

The specification also includes provisions providing requirements for ductility of steel used for cold-formed applications. The design methods and requirements are outlined in the following sections.

2.2.4.1. Pure shear. The nominal shear strength shall be calculated as follows:
for $t_2/t_1 \leq 1.0$, P_{ns} shall be taken as the smaller of

$$P_{ns} = 4.2(t_2^3 d)^{1/2} F_{u2} \quad (2-10)$$

$$P_{ns} = 2.7t_1 d F_{u1} \quad (2-11)$$

$$P_{ns} = 2.7t_2 d F_{u2} \quad (2-12)$$

for $t_2/t_1 \geq 2.5$, P_{ns} shall be taken as the smaller of

$$P_{ns} = 2.7t_1 d F_{u1} \quad (2-13)$$

$$P_{ns} = 2.7t_2 d F_{u2} \quad (2-14)$$

for $1.0 < t_2/t_1 < 2.5$, P_{ns} shall be calculated by linear interpolation between the above two cases.

where:

d = nominal screw diameter

P_{ns} = nominal shear strength per screw

t_1 = thickness of member in contact with screw head or washer

t_2 = thickness of member not in contact with screw head or washer

F_{u1} = tensile strength of member in contact with screw head or washer

F_{u2} = tensile strength of member not in contact with screw head or washer

2.2.4.2. Pure tension pull-out. The nominal pull-out strength shall be calculated as follows:

$$P_{not} = 0.85t_c d F_{u2} \quad (2-15)$$

where:

d = nominal screw diameter

t_c = lesser of the depth of penetration and thickness t_2

P_{not} = nominal pull-out strength per screw

F_{u2} = tensile strength of member not in contact with screw head or washer

2.2.4.3. Pure tension pull-over. The nominal pull-over strength shall be calculated as follows:

$$P_{nov} = 1.5t_1 d_w' F_{u1} \quad (2-16)$$

where:

t_1 = thickness of member in contact with screw head or washer

P_{nov} = nominal pull-over strength per screw

F_{u1} = tensile strength of member in contact with screw head or washer

d_w' = effective pull-over diameter determined in accordance with (a), (b), or (c) as

follows:

(a) for a round head, a hex head, or hex washer head screw with an independent and solid steel washer beneath the screw head

$$d_w' = d_h + 2t_w + t_1 \leq d_w$$

where

d_h = screw head diameter or hex washer integral washer diameter

t_w = steel washer thickness

d_w = steel washer diameter

(b) for a round head, a hex head, or hex washer head screw without an independent washer beneath the screw head:

$d_w' = d_h$ but not larger than $\frac{1}{2}$ in.

(c) for a domed (non-solid and independent) washer beneath the screw head, it is permissible to use d_w' as calculated in (a), with d_h as the washer diameter, t_w as the thickness of the material of the washer, and t_1 as previously defined. In the equation in (a), d_w' cannot exceed $\frac{5}{8}$ in. Alternatively, pull-over design values for domed washers, including the safety factor, Ω , and the resistance factor, ϕ , shall be permitted to be determined by test in accordance with Chapter F.

2.2.4.4. Combined pull-over and shear. For screw connections subject to combined tension and shear the following requirements shall be met.

for ASD Method

$$\frac{Q}{P_{ns}} + 0.71 \frac{T}{P_{nov}} \leq \frac{1.10}{\Omega} \quad (2-17)$$

for LRFD and LSD Methods

$$\frac{\bar{Q}}{P_{ns}} + 0.71 \frac{\bar{T}}{P_{nov}} \leq 1.10\phi \quad (2-18)$$

where:

Q = required allowable shear strength of connection

T = required allowable tension strength of connection

P_{ns} = nominal shear strength per screw

$$P_{ns} = 2.7t_1dF_{ul}$$

P_{nov} = nominal pull-over strength of connection

$$P_{nov} = 1.5t_1d_wF_{ul}$$

where d_w = larger of screw head diameter or washer diameter

$$\Omega = 2.35$$

Q = required allowable shear strength of connection

T = required allowable tension strength of connection

P_{ns} = nominal shear strength per screw

$$P_{ns} = 2.7t_1dF_{ul}$$

P_{nov} = nominal pull-over strength of connection

$$P_{nov} = 1.5t_1d_wF_{ul}$$

where d_w = larger of screw head diameter or washer diameter

\bar{Q} = required shear strength of connection

$\bar{Q} = V_u$ for LRFD

$\bar{Q} = V_f$ for LSD

\bar{T} = required shear strength of connection

$\bar{T} = V_u$ for LRFD

$\bar{T} = V_f$ for LSD

$$\phi = 0.65 \text{ (LRFD)}$$

$$\phi = 0.55 \text{ (LSD)}$$

Equations 2-16 and 2-17 shall be valid for connections that meet the following limits:

- (1) $0.0285 \text{ in.} \leq t_1 \leq 0.0455 \text{ in.}$,
- (2) No. 12 and No. 14 self-drilling screws with or without washers,
- (3) $d_w \leq 0.75 \text{ in.}$,
- (4) $F_{u1} \leq 70 \text{ ksi}$, and
- (5) $t_2/t_1 \geq 2.5$

2.2.4.5. Ductility. The specification requires that all steels used for structural applications and connections meet the requirements in Section A2.3. For normal ductility steels Section A2.3.1 applies. The ratio of tensile strength to yield stress, F_u/F_y , shall not be less than 1.08 and the total elongation shall not be less than 10 percent for a two-inch gage length (AISI 2007). If these requirements cannot be met other criteria may be satisfied for restricted use in purlins, girts, and curtain wall studs (AISI 2007).

For low ductility steels Section A2.3.2 applies. Steels that do not meet the minimum 10 percent elongation requirement may be used for limited applications conforming to several exceptions provided that the steel meet certain requirements. First, the yield stress, F_y , used for determining nominal strength is taken as 75 percent of the specified minimum yield stress or 60 ksi, whichever is less (AISI 2007). Second, the tensile strength, F_u , used for determining nominal strength in connections is taken as 75 percent of the minimum tensile strength or 62 ksi, whichever is less (AISI 2007).

3. EXPERIMENTAL INVESTIGATION

3.1. INTRODUCTION

This study included a test program at Missouri S&T to examine the relationship between combined pull-out and shear loading of screw connections in cold-formed steel. Once the scope of the study was established based on previous research as reviewed in Section 2, specimens and a test fixture were designed. The test fixture was modified from previous research by Stirnemann and LaBoube that evaluated combined tension and shear forces on arc spot weld connections. Finally, tests were conducted and the data was analyzed to ascertain design method recommendations. A total of eighty-four tests were performed.

3.2. SCOPE OF INVESTIGATION

A review of the current AISI specification, determined that parameters influencing sheet steel screw connections may be the thickness of the sheet not in contact with the screw head or washer, the tensile strength of the material, the ductility of the material, and the screw diameter. Once testing commenced, the specimens appeared to be influenced by the stiffness of the specimen's elements. Nine specimens with edge stiffeners were fabricated, and specimen stiffness was evaluated before continuing the investigation.

3.2.1. Material Properties. The mechanical properties of the sheet steel used in this investigation were determined by performing tensile coupon tests. Each coupon test was carried out in accordance with ASTM A 370 *Standard Test Methods and Definitions for Mechanical Testing of Steel Products* (ASTM 2007). Two coupon tests were

completed for each steel grade and sheet thickness, and the results of the tests were averaged.

The properties obtained were uncoated thickness, yield stress, and tensile strength. The notations N and L were assigned to normal- and low-ductility steels, respectively. Table 3.1 summarizes the results of the coupon tests.

Table 3.1 Material Properties

Specimen	Uncoated Thickness	Yield Stress	Tensile Strength	F_u/F_y	Elongation
	t (in)	F_y (ksi)	F_u (ksi)		%
20N	0.0297	41.41	48.295	1.166	42.58
18N	0.0394	29.25	47.315	1.618	38.38
16N	0.0521	62.205	75.49	1.214	29.69
14N	0.0724	68.39	74.32	1.087	34.38
20L	0.0327	102.75	105.99	1.032	2.34
18L	0.0375	91.175	91.18	1.000	1.17
16L	0.0508	84.25	89.645	1.064	3.91
14L	0.0675	117	120.565	1.030	2.73

3.2.2. Test Variables. The variables for the test specimens were the parameters listed in Section 3.2 above. The self-drilling, self-tapping screws used for the test program included No. 8 (0.164 in.), No. 10 (0.190 in.), No.12 (0.216 in.), and No. 14 (0.240 in.) sizes; they are pictured in Figure 3.1. Table 3.1 lists the test variable data.



Figure 3.1 Self-Drilling Screws

An additional test variable that was not a test specimen parameter was the angle of rotation. The load was applied vertically, and the angle of the test specimen was varied. The majority of the tests used three angles; fifteen degrees, thirty degrees, and sixty degrees, but a few tests were also completed at seventy-five degrees. The variation in the angle of rotation induced various combinations of tension and shear forces, thus providing a better range of data and clarified the interaction of pull-out and shear. Figure 3.2 shows the angles of rotation.

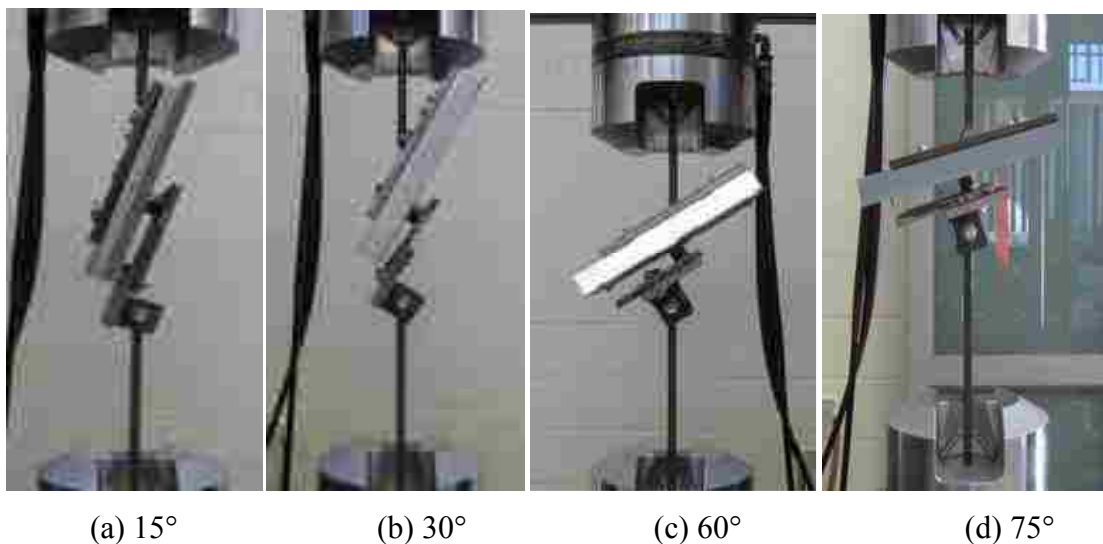

(a) 15°

(b) 30°

(c) 60°

(d) 75°

Figure 3.2 Angles of Rotation

3.3. TEST SPECIMEN AND TEST FIXTURE

3.3.1. Test Specimen: Parameters. Each test specimen was fabricated and assembled at Missouri S&T. All nominal dimensions are shown in Figure 3.3.

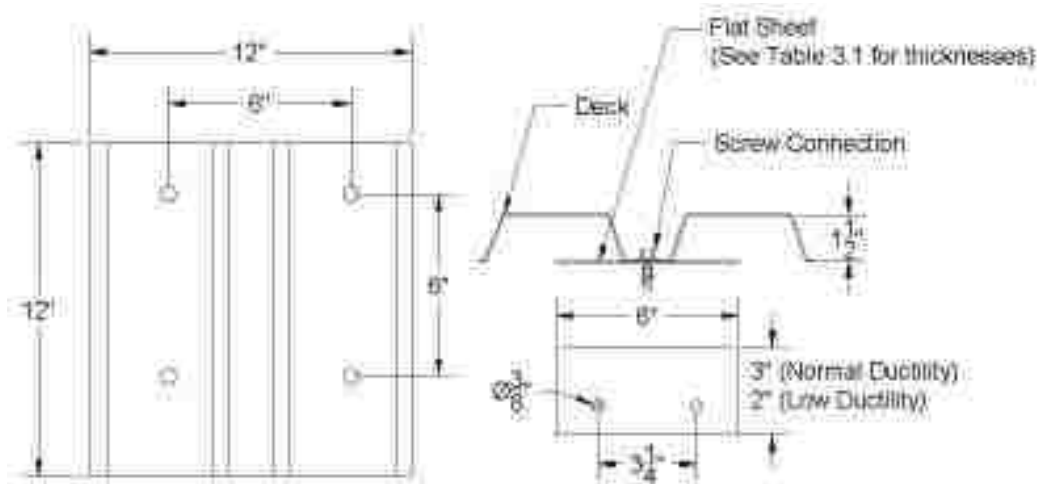

Figure 3.3 Test Specimen Nominal Dimensions

3.3.2. Test Specimen: Fabrication. The test specimen consisted of a cold-formed steel deck section screwed to a flat sheet (Figures 3.3 and 3.4). For pull-out, the critical component of the test specimen was the cold-formed steel flat sheet, which measured 3 in. x 36 in. for the normal-ductility steel and 2 in. x 36 in. for the low-ductility steel.

Using a metal cutting wheel on a miter saw, the steel sheets were cut to 6 in. long (Figure 3.3). The dimensions of each flat sheet varied slightly; however, variations were negligible and did not affect the bolting pattern to the test fixture. Two holes were then drilled at a 3 1/4 in. spacing to connect the specimen to the test fixture. This drilling was

performed on a digital readout milling machine to ensure accuracy. Prior to connecting a flat sheet to the deck, a mark was made $1 \frac{7}{16}$ in. from the edge of either hole to ensure that the screw would be properly installed on center so the test specimen would be concentrically loaded.



Figure 3.4 Typical Test Specimen

Each test specimen was assigned a unique serial number so it could be cataloged and matched later with the appropriate photos and data. Using 14L12-30-1 as an example, the first two digits of the serial number designate the gage (thickness) of the steel. The letter N or L indicates whether it is a normal- (N) or low- (L) ductility steel. The following digits indicate the screw size and the angle of rotation, separated by hyphens. A final digit indicates whether the test specimen is the first or second for a specific arrangement of variables. Figure 3.5 shows prepared normal- and low-ductility flat sheets.

Cold-formed steel deck was incorporated in the test specimen as the top sheet for the connection. The deck was 12 in. x 12 in., and four holes were drilled in it to connect it to the upper test fixture. Since this study forced pull-out of the bottom sheet, the deck

was used only for the connection, and the thickness was recorded only to determine the t_2/t_1 range. The t_2/t_1 range was 0.325 to 2.454.



Figure 3.5 Normal- and Low-Ductility Flat Sheets

3.3.3. Test Fixture. Stirnemann's basic test fixture consisted of a welded T-section and a rotating arm. The welded T-section (Figure 3.6) was made of a flat plate welded to a stem plate (Stirnemann 2006). Three welded T-sections were fabricated at 30°, 60°, and 75°. The angle was measured from the vertical of the welded T-section. Once the testing using the 75° T-section was complete, that it was modified to 15°. The lower fixture was made of two 2-in.-square plates welded to a main base plate. The arm rotated on a ½ in. diameter bolt running through the 2-in. plates. Figure 3.7 shows the rotating arm.

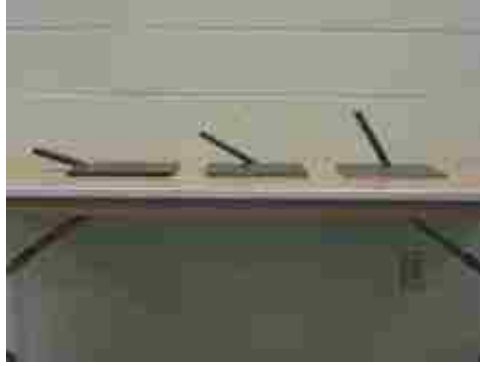

Figure 3.6 Upper Fixture: Welded T-Sections 15°, 30°, and 60°

Stirnemann's fixture was modified for the present study by bolting a specially fabricated plate to the lower fixture. The plate had two threaded rods that permitted suspension of the flat sheet. This arrangement allowed the screw to fall freely below the flat sheet while remaining securely bolted to the lower arm. Figure 3.8 shows a test specimen bolted to the modifying specimen plate and attached to the rotating arm.



Figure 3.7 Lower Fixture: Rotating Arm

3.3.4. Test Setup. For ease of assembly, the flat sheet was first bolted to the lower test fixture comprised of the rotating arm and the modification plate (Figures 3.7 and 3.8). A pre-drilled hole through the deck accommodated the angle of rotation for a given test. This hole permitted the concentric alignment of the deck and the flat sheet with the test fixture and testing machine after the test specimen was mounted. A screw was then inserted through the pre-drilled hole to connect the flat sheet to the deck. Once the deck was attached to the flat sheet, the upper piece of the test fixture (Figure 3.6) was then bolted to the deck, and the entire prepared test setup and fixture was then mounted in the testing machine. Figure 3.2 shows the test setup.



Figure 3.8 Modification Plate

3.3.5. Test Procedure. Each prepared test specimen was mounted in an MTS 880 Material Test System (Figure 3.9). A computer data acquisition system recorded the load and displacement during each test. The load rate was 1/16 in. per minute. Load and displacement were recorded for each test at eight intervals per second to ensure that the maximum load was recorded.



Figure 3.9 MTS 880 Material Test System

During testing, distortion of the flat sheet was observed that indicated the stiffness of flat sheet in the test specimen (Figure 3.3) should be evaluated. Normal-ductility test specimens (Figure 3.5) were stiffened using a brake press. Each of the long sides was bent to form $\frac{1}{2}$ in. edge stiffeners (Figure 3.10). The specimen was setup and tested using the same methods described in Sections 3.3.4 and 3.3.5.



Figure 3.10 Flat Sheet with Edge Stiffeners

Six tests were initially performed to evaluate stiffness and determine whether it influenced the interaction of combined pull-out and shear loading. The same tests were performed on the un-stiffened counterparts of each specimen. Table 3.2 compares the results of both tests for the three primary angles of rotation.

Table 3.2 Comparison of Stiffened versus Un-stiffened Specimens

		Ultimate Strength (lbf)					
		Un-stiffened Specimen		Average	Stiffened Specimen		Average
Angle of Rotation	15°	468.8	494.3	481.6	374.3	452.4	413.4
	30°	352.7	353.6	353.2	321.1	365.3	343.2
	60°	320.9	337.6	329.3	317.7	323.5	320.6

Tilting of the screw and tearing were the failure modes observed in both specimens (Figure 3.11). Based on Table 3.2 and a comparison of the load versus deflection curves (an example of which is given in Figure 3.12), the stiffness of the test specimens at 30° and 60° did not affect the overall strength of connections subject to combined pull-out and shear. The test results for the stiffened flat sheet at 15° were inconclusive therefore more tests were performed.

Three additional tests were performed to confirm that the test angle 15° was not affected by the stiffness of the specimen. During testing of the three additional tests, it was observed that the first test resulting in an ultimate strength of 392.5 lbf was loose, or there was slack, between the connecting members. This could be contributing to the lower ultimate strength. It was also observed during the second and third tests that there

was no slack between the connecting sheets. These values are more comparable to the un-stiffened flat sheets and the stiffened flat sheet with an ultimate capacity of 452.4 lbf. After reviewing Table 3.3, it can be concluded that the low test values may not be representative of a proper screw connection and that the stiffness at 15° did not affect the test specimen's results.



Figure 3.11 Comparison of Stiffened versus Un-stiffened Failure Modes

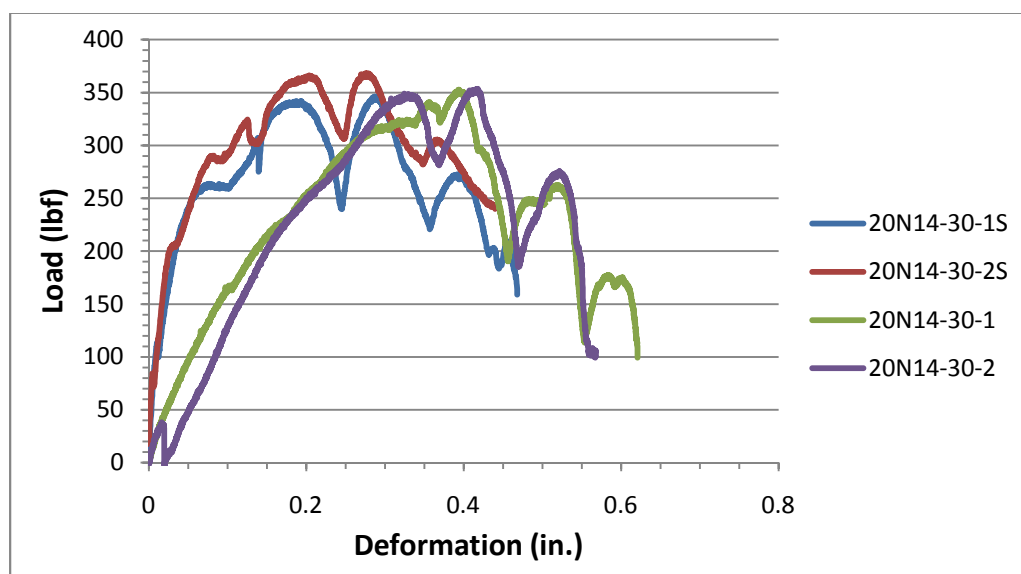

Figure 3.12 Load versus Deflection of 30° Test Specimens

Table 3.3 Comparison of all Stiffened versus Un-stiffened Specimens at 15°

Ultimate Strength (lbf)								
Un-stiffened Specimen		Average	Stiffened Specimen					Average*
468.8	494.3	481.6	374.3	452.4	392.5	445.7	467.1	455.1

*Stiffened Specimen Average is based on values excluding data less than 445.7 lbf.

3.4. TEST RESULTS

A total of eighty four tests were performed. Thirty-nine were normal-ductility test specimens, and thirty-six were low-ductility test specimens. Nine additional tests were performed to evaluate specimen stiffness, as explain in Section 3.3.5.1.

Each test specimen was tested until failure. If the screw failed, the test was classified as inconclusive for purposes of this study and removed from the results. Screw failures occurred only in angles introduced to larger shear components, specifically 15° and 30°.

In most respects, the specimens behaved similarly for all tests. The typical failure mode observed in all tests was a combination of screw pull-out (tension failure), tilting of the screw (shear failure), and bearing of the sheet (shear failure). The normal- and low-ductility specimens did perform differently with respect to deformation and strength. These results are described in Sections 3.4.1 and 3.4.2.

For screw connections, the load versus displacement curve varied with each test. An example of such a curve is shown in Figure 3.13. The peaks of the curve represent the points at which the threads of the screw were pulled through the hole. As each layer of threads caught the sheet, the connection gained strength until it reached the peak

strength of those threads and so on and so forth. The ultimate strength of the connection depended on the highest load carried during loading, regardless of deformation.

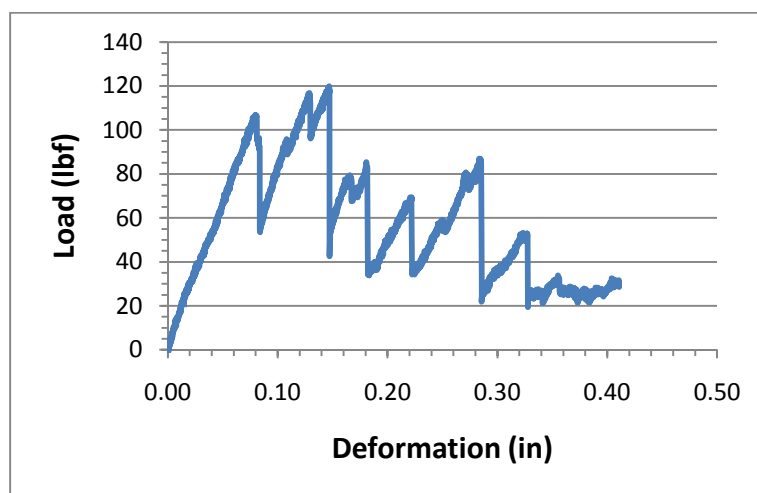

Figure 3.13 Example Load versus Deformation Curve

3.4.1. Normal-Ductility Specimens. All normal-ductility specimens experienced plastic deformation. Figure 3.14 shows a typical normal-ductility specimen after testing. Given the same sheet thickness and screw diameter, the normal-ductility steel deformed more than the low-ductility steel, and tearing of the sheet was more prominent. Figure 3.15 shows a normal-ductility specimen above a low-ductility specimen. The normal-ductility specimens also had a higher ratio of ultimate strength to nominal strength given the same setup. The distortion of the sheet was typical of all normal-ductility specimens. This distortion of deformation was not an effect of eccentricity, but rather of the combination of the pull-out and shear forces.

The ultimate strength, P_u , was determined from the recorded data. Based on the angle of the test, the ultimate tension and ultimate shear forces P_{ut} and P_{uv} , respectively, were calculated using basic trigonometry. Table A.1 in Appendix A shows the test results for the normal-ductility specimens.



Figure 3.14 Typical Normal-Ductility Flat Sheet after Testing



Figure 3.15 Comparison of Normal- and Low-Ductility Flat Sheets

3.4.2. Low-Ductility Specimens. Low-ductility specimens typically experienced less plastic deformation than the normal-ductility specimens. Figure 3.15 shows a low-ductility specimen (bottom) and a normal-ductility specimen (top). The low-ductility specimens had less deformation, and tilting of the screw was more prominent due to the resistance of the steel to allow tearing to occur (Figure 3.16). The low-ductility specimens overall had lower ratios of ultimate strength to nominal strength than the normal-ductility specimens. The same distortion effects observed in the normal-ductility specimens were apparent in the low-ductility tests, but they were typically less prominent. Many low-ductility specimens never reached inelasticity, and deformation was not permanent.



Figure 3.16 Typical Low-Ductility Flat Sheet after Testing

The ultimate strength, P_u , was determined as for normal-ductility specimens (see Section 3.4.1. above). The tension and shear components were also determined as for normal-ductility specimens (see Section 3.4.1 above). Table A.2 in Appendix A shows the test results for low-ductility specimens.

4. DATA ANALYSIS

4.1. INTRODUCTION

Test data was evaluated using the pull-out and shear design equations for screw connections from the 2007 specification. Based on the relationship or interaction between the tension and shear forces, specifically pull-out tension forces two design equations were formulated.

4.2. DATA ANALYSIS USING AISI EQUATIONS

4.2.1. Data for Analysis. Using design Equations 2-10 through 2-15, the nominal strengths were calculated for pull-out, P_{not} , and shear, P_{ns} . The ultimate load applied to each test specimen was evaluated for its tension and shear components, P_{ut} and P_{uv} , respectively. These ultimate strength components were then normalized using the nominal strength equations to form the ratios P_{ut}/P_{not} and P_{uv}/P_{ns} . Tables B.1 and B.2 show the results for the normal- and low-ductility test data, respectively.

4.2.2. Evaluating Screw Diameter. Based on previous research discussed in Section 2, one parameter thought to influence pull-out and shear interaction was the diameter of the screw. All tests performed for the 30° angle configuration used the entire range of screw sizes (No. 8, 10, 12, and 14). Figures 4.1 and 4.2 show a graph of the normalized shear strength, P_{uv}/P_{ns} , versus the normalized pull-out strength, P_{ut}/P_{not} , at 30° only for the normal-ductility and low-ductility specimens, respectively.

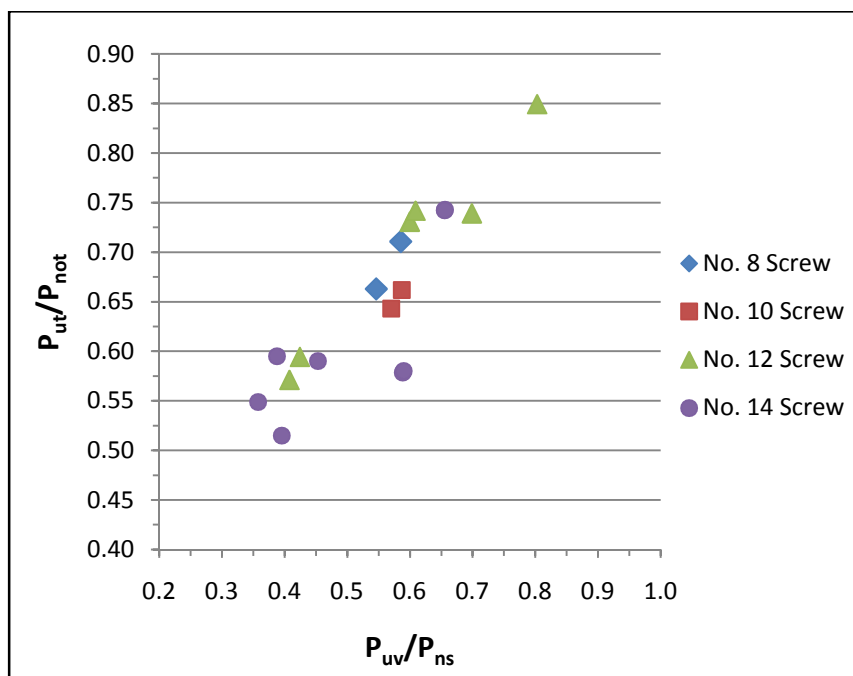

Figure 4.1 Evaluation of Screw Size at 30° - Normal Ductility

Based on the distribution of the data for all screw diameters at 30° although screw diameter affected the overall strength of the connection, it did not influence the interaction of the combined loading. These conclusions justified a reduction in the number of tests required for this study. The other test angle configurations were tested using only one screw size. At 60° No. 10 screws were used. At 15°, however, No. 14 screws were used due to the large shear loads being induced. The few tests performed at 75° degrees used No. 8 and No. 10 screws.

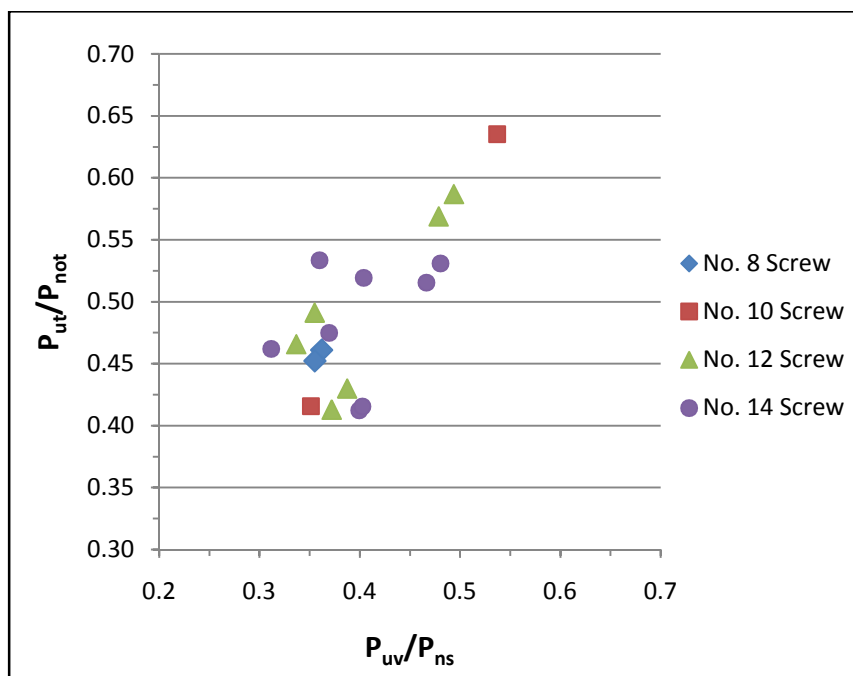

Figure 4.2 Evaluation of Screw Size at 30° – Low Ductility

4.2.3. Shear versus Pull-out. To review the interaction between pull-out and shear of screw connections, Figure 4.3 shows the ratios of ultimate strength to nominal strength, P_{uv}/P_{ns} versus P_{ut}/P_{not} . A relationship is apparent between the interaction of pull-out and shear. The data approaches 1.0 on both axes where pure shear or pure tension would occur. For normal-ductility specimens, this interaction seems acceptable, but it is overestimated for the low-ductility specimens. Due to this overestimation an adjustment factor, L , was used to develop the interaction equations in Section 4.3.

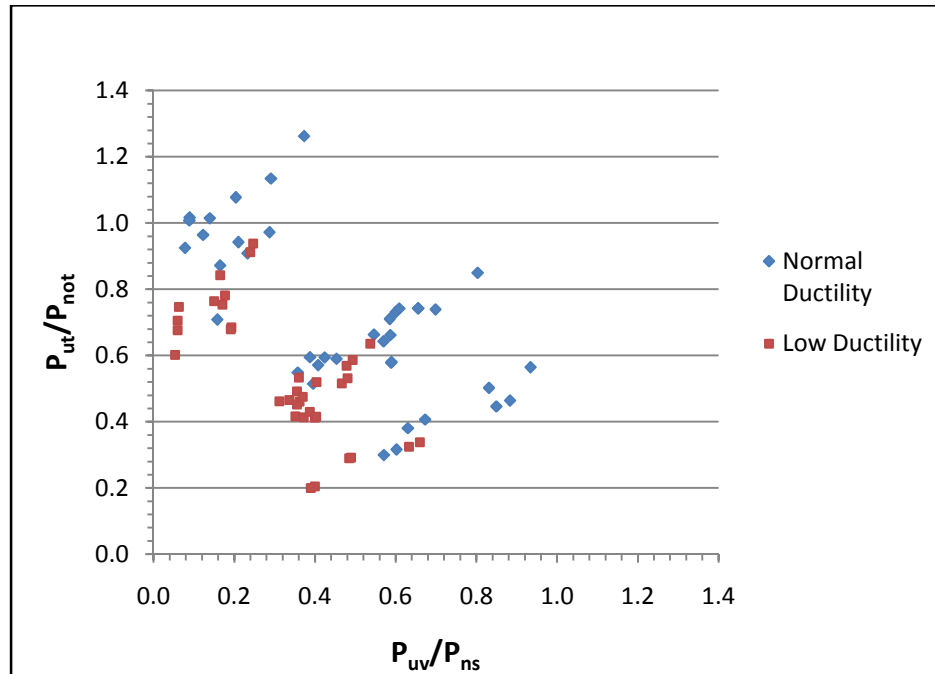

Figure 4.3 Pull-out and Shear Interaction using AISI Equations

4.3. DEVELOPMENT OF INTERACTION EQUATION

Several nonlinear and linear interaction equations were investigated based on mean, standard deviation, and coefficient of variation. An adjustment factor, L , was used for low-ductility steel. The following proposes best-fit cases for a tri-linear and nonlinear interaction equation.

4.3.1. Tri-Linear Interaction Equation. The proposed tri-linear interaction equation, Equation 4-1, was derived using the data shown in Figure 4.3. The values can be found in Tables B.1 and B.2 of Appendix B. The mean value and coefficient of variation were used to determine the resistance and safety factors (ϕ for LRFD and LSD, and Ω for ASD). These values can be found in Appendix C. Equation 2-10 controlled for nominal shear strength in all but one case. Thus Equation 2-10 is proposed as a

means to calculate the interaction of pull-out and shear. Figure 4.4 shows the results of Equation 4-1, along with the normal- and low-ductility test data.

when: $P_{uv}/P_{ns} \geq 0.15$ and $P_{ut}/P_{not} \geq 0.15$

$$\frac{P_{uv}}{LP_{ns}} + \frac{P_{ut}}{LP_{not}} \leq 1.15 \quad (4-1)$$

where:

$$L = 1.0, \text{ for } F_u/F_y \geq 1.087,$$

$$L = 0.75, \text{ for } F_u/F_y \leq 1.064,$$

$$P_{ns} = 4.2(t_2^3 d)^{1/2} F_{u2} \quad (\text{nominal shear strength of connection Equation 2-10})$$

$$P_{not} = 0.85t_c d F_{u2} \quad (\text{nominal pull-out strength of connection Equation 2-15})$$

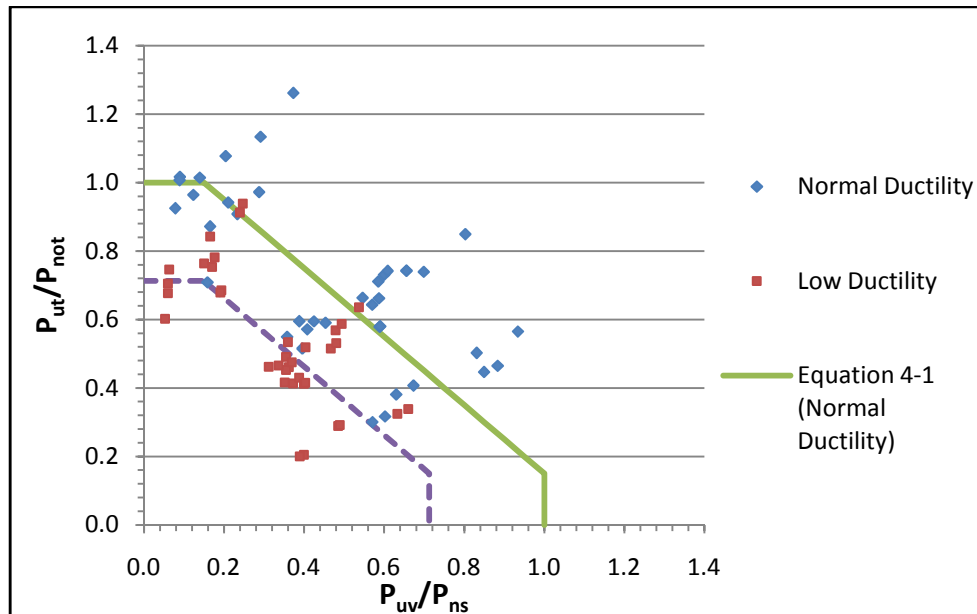

Figure 4.4 Tri-Linear Equation Interaction Relationship

4.3.2. Nonlinear Interaction Equation. The proposed nonlinear interaction equation is Equation 4-2 and is shown in Figure 4.5. It was derived using the data shown in Figure 4.3 and from Tables B.1 and B.2 of Appendix B. The mean value and coefficient of variation were used to determine the resistance and safety factors and can be found in Tables D.1 and D.2 of Appendix D.

$$\left(\frac{P_{uv}}{LP_{ns}} \right)^{1.15} + \left(\frac{P_{ut}}{LP_{not}} \right)^{1.15} \leq 1.0 \quad (4-2)$$

where:

$$L = 1.0, \text{ for } F_u/F_y \geq 1.087,$$

$$L = 0.80, \text{ for } F_u/F_y \leq 1.064,$$

$$P_{ns} = 4.2(t_2^3 d)^{1/2} F_{u2} \quad (\text{nominal shear strength of connection Equation 2-10})$$

$$P_{not} = 0.85t_c d F_{u2} \quad (\text{nominal pull-out strength of connection Equation 2-15})$$

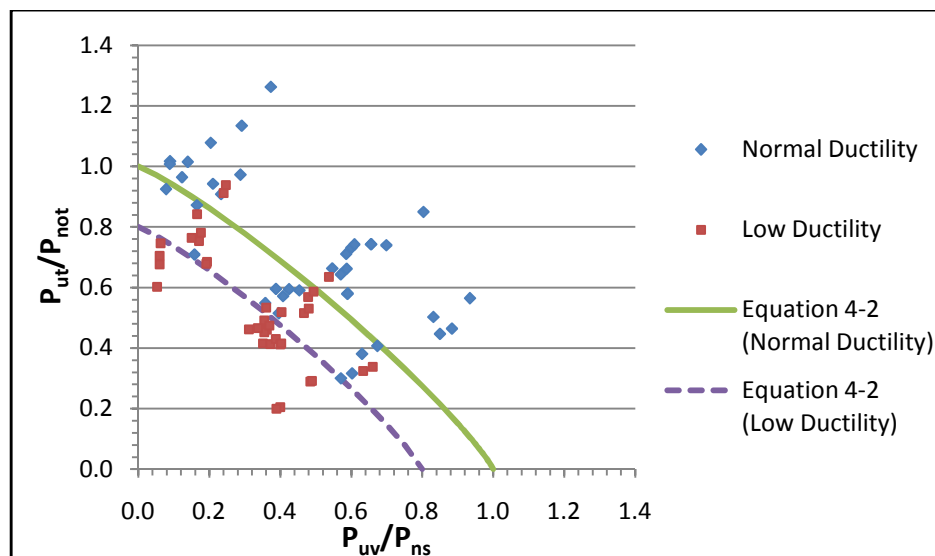

Figure 4.5 Nonlinear Equation Interaction Relationship

5. SUMMARY AND DESIGN RECOMMENDATIONS

5.1. SUMMARY

This study assessed the interaction relationship between pull-out and shear forces in screw connections in cold-formed structural steel. A total of eighty four tests were performed. The test data was analyzed using AISI Equations 2-10 through 2-15; and two equations, 5-1 and 5-2, are proposed for use in designing screw connections subject to this limit state.

5.2. DESIGN RECOMMENDATIONS

For the design method recommended in this section, the adjustment factor L was removed because, in accordance with Section A.2.3.2 of the AISI specification a 25% reduction in tensile strength, F_u , is required for low-ductility steels (AISI 2007). Using the adjustment factor, therefore would account twice for the adjustment for low-ductility steel. Section 4 demonstrates that this is accurate for the tri-linear equation where L equals 0.75, and slightly conservative for the nonlinear equation where L equals 0.80. Changes to the adjustment factor for the nonlinear equation were made to correlate with an L equal to 0.75. Table D.3 in Appendix D shows the correlations and statistical analysis based on this adjustment. While an L of 0.75 did not provide the best results for a statistical analysis of the nonlinear equation, it does provide acceptable values, and conservatively shift the adjustment factor allowing for the removal of the adjustment factor. The following interaction equations are proposed to calculate the design capacity of a screw connection subject to combined pull-out and shear forces.

Tri-Linear Equation:

For ASD:

when: $P_{uv}/P_{ns} > 0.15$ and $P_{ut}/P_{not} > 0.15$

$$\frac{Q}{P_{ns}} + \frac{T}{P_{not}} \leq \frac{1.15}{\Omega} \quad (5-1)$$

For LRFD and LSD:

when: $P_{uv}/P_{ns} \geq 0.15$ and $P_{ut}/P_{not} \geq 0.15$

$$\frac{\bar{Q}}{P_{ns}} + \frac{\bar{T}}{P_{not}} \leq 1.15\phi \quad (5-2)$$

where: $P_{ns} = 4.2(t_2^3 d)^{1/2} F_{u2}$ (nominal shear strength of connection Equation 2-10)

$P_{not} = 0.85t_c d F_{u2}$ (nominal pull-out strength of connection Equation 2-15)

$\Omega = 2.54$ for United States and Mexico

$\phi = 0.60$ for United States and Mexico

$\phi = 0.51$ for Canada

Non-Linear Equation:

For ASD:

$$\left(\frac{Q}{P_{ns}} \right)^{1.15} + \left(\frac{T}{P_{not}} \right)^{1.15} \leq \frac{1.0}{\Omega} \quad (\text{Eq. 5-3})$$

For LRFD and LSD:

$$\left(\frac{\bar{Q}}{P_{ns}} \right)^{1.15} + \left(\frac{\bar{T}}{P_{not}} \right)^{1.15} \leq 1.0\phi \quad (\text{Eq. 5-4})$$

where: $P_{ns} = 4.2(t_2^3 d)^{1/2} F_{u2}$ (nominal shear strength of connection Equation 2-10)

$P_{not} = 0.85t_c d F_{u2}$ (nominal pull-out strength of connection Equation 2-15)

for $F_u/F_y \geq 1.087$,

$\Omega = 2.65$ for United States and Mexico

$\phi = 0.58$ for United States and Mexico

$\phi = 0.48$ for Canada

for $F_u/F_y \leq 1.064$,

$\Omega = 2.51$ for United States and Mexico

$\phi = 0.61$ for United States and Mexico

$\phi = 0.51$ for Canada

Equation Limitations:

$0.0297 \text{ in.} \leq t_2 \leq 0.0724 \text{ in.}$

$F_{u2} \leq 121 \text{ ksi}$

No. 8, 10, 12, or 14 screws, with or without washers

$1.0 \leq F_u/F_y \leq 1.618$

where: All test parameters for both the tri-linear and nonlinear equations are defined in

Section 2.2.4.

6. RECOMMENDATIONS FOR FUTURE RESEARCH

This study took into consideration only concentric loading. However, eccentricity can drastically change the amount of tension or shear applied in screw connections. More research is required to validate the proposed equations for eccentric loading or to develop a new design methodology for eccentric connections subject to combined forces, such as clip angles.

Previous research by Ellifritt and Burnette has also shown that real-world situations can reduce the capacity of screw connections subject to pull-over. Such situations should, therefore, be simulated and evaluated for combined pull-out and shear connections.

Other considerations that could affect the design methods proposed here include multiple sheet connections, insulation between the sheets or gap tolerances in the connection, and screw connections outside the limitations of this research.

APPENDIX A

RESULTS OF TEST DATA

Table A.1 Test Data for Normal-Ductility Specimens

Specimen No.	Specimen Angle	P _u (lbf)
20N08-30-1	30	284.2
20N08-30-2	30	265.1
20N10-30-1	30	297.9
20N10-30-2	30	306.6
20N12-30-1	30	447.4
20N12-30-2	30	389.4
20N14-30-1	30	352.7
20N14-30-2	30	353.6
20N10-60-1	60	260.1
20N10-60-2	60	337.6
20N14-15-1	15	468.6
20N14-15-2	15	494.3
18N12-30-1	30	500.3
18N12-30-2	30	507.8
18N14-30-1	30	588.5
18N14-30-2	30	588.1
18N10-60-1	60	394.2
18N10-60-2	60	315.7
18N14-15-1	15	683.4
18N14-15-2	15	710.7

Specimen No.	Specimen Angle	P _u (lbf)
16N12-30-1	30	858.5
16N12-30-2	30	825.0
16N14-30-1	30	860.7
16N14-30-2	30	986.6
16N10-60-1	60	519.7
16N10-60-2	60	691.1
16N14-15-1	15	1229.9
16N14-15-2	15	1314.0
14N14-30-1	30	1255.0
14N14-30-2	30	1360.8
14N10-60-1	60	1081.3
14N10-60-2	60	874.6
14N14-15-1	15	1622.3
14N14-15-2	15	1823.3
20N08-75-1	75	199.6
20N10-75-1	75	243.3
14N08-75-1	75	718.3
14N10-75-1	75	914.7
14N10-75-2	75	906.4

Table A.2 Test Data for Low-Ductility Specimens

Specimen No.	Specimen Angle	P _u (lbf)
20L08-30-1	30	445.5
20L08-30-2	30	437.1
20L10-30-1	30	711.3
20L10-30-2	30	465.5
20L12-30-1	30	525.6
20L12-30-2	30	547.3
20L14-30-1	30	607.3
20L14-30-2	30	612.1
20L10-60-1	60	443.0
20L10-60-2	60	438.8
20L14-15-1	15	668.7
20L14-15-2	15	651.6
18L12-30-1	30	714.1
18L12-30-2	30	736.7
18L14-30-1	30	749.0
18L14-30-2	30	771.4
18L10-60-1	60	598.2
18L10-60-2	60	581.5

Specimen No.	Specimen Angle	P _u (lbf)
18L14-15-1	15	911.2
18L14-15-2	15	950.0
16L12-30-1	30	821.4
16L12-30-2	30	778.9
16L14-30-1	30	1004.9
16L14-30-2	30	919.1
16L10-60-1	60	663.4
16L10-60-2	60	640.2
16L14-15-1	15	1081.5
16L14-15-2	15	1092.0
14L14-30-1	30	1597.4
14L14-30-2	30	1845.0
14L10-60-1	60	1159.5
14L10-60-2	60	1278.4
14L08-75-1	75	887.8
14L08-75-2	75	940.4
14L10-75-1	75	878.8
14L10-75-2	75	987.4

APPENDIX B

ANALYSIS OF TEST DATA

Table B.1 Analyzed Test Data for Normal-Ductility Specimens

Specimen No.	P_u (lbf)	P_{ut} (lbf)	P_{uv} (lbf)	P_{not} (lbf)	P_{ns} (lbf)	$\frac{P_{ut}}{P_{not}}$	$\frac{P_{uv}}{P_{ns}}$
20N08-30-1	284.2	142.1	246.1	199.9	420.4	0.711	0.585
20N08-30-2	265.1	132.6	229.6	199.9	420.4	0.663	0.546
20N10-30-1	297.9	149.0	258.0	231.6	452.5	0.643	0.570
20N10-30-2	306.6	153.3	265.6	231.6	452.5	0.662	0.587
20N12-30-1	447.4	223.7	387.4	263.3	482.5	0.849	0.803
20N12-30-2	389.4	194.7	337.2	263.3	482.5	0.739	0.699
20N14-30-1	352.7	176.4	305.5	304.8	519.1	0.579	0.588
20N14-30-2	353.6	176.8	306.2	304.8	519.1	0.580	0.590
20N10-60-1	260.1	225.3	130.1	231.6	452.5	0.972	0.287
20N10-60-2	337.6	292.4	168.8	231.6	452.5	1.262	0.373
20N14-15-1	468.6	121.3	452.6	404.3	793.2	0.300	0.571
20N14-15-2	494.3	127.9	477.5	404.3	793.2	0.316	0.602
18N12-30-1	500.3	250.1	433.2	342.3	722.3	0.731	0.600
18N12-30-2	507.8	253.9	439.8	342.3	722.3	0.742	0.609
18N14-30-1	588.5	294.2	509.6	396.1	777.1	0.743	0.656
18N14-30-2	588.1	294.1	509.3	396.1	777.1	0.742	0.655
18N10-60-1	394.2	341.4	197.1	301.1	677.4	1.134	0.291
18N10-60-2	315.7	273.4	157.9	301.1	677.4	0.908	0.233
18N14-15-1	683.4	176.9	660.1	396.1	777.1	0.447	0.849

Specimen No.	P_u (lbf)	P_{ut} (lbf)	P_{uv} (lbf)	P_{not} (lbf)	P_{ns} (lbf)	$\frac{P_{ut}}{P_{not}}$	$\frac{P_{uv}}{P_{ns}}$
18N14-15-2	710.7	183.9	686.5	396.1	777.1	0.464	0.883
16N12-30-1	858.5	429.2	743.5	722.1	1752.4	0.594	0.424
16N14-30-1	860.7	430.3	745.3	835.8	1885.2	0.515	0.395
16N14-30-2	986.6	493.3	854.4	835.8	1885.2	0.590	0.453
16N10-60-1	519.7	450.1	259.9	635.2	1643.5	0.709	0.158
16N10-60-2	691.1	598.5	345.5	635.2	1643.5	0.942	0.210
16N14-15-1	1229.9	318.3	1188.0	835.8	1885.2	0.381	0.630
16N14-15-2	1314.0	340.1	1269.2	835.8	1885.2	0.407	0.673
14N14-30-1	1255.0	627.5	1086.9	1143.4	3040.4	0.549	0.357
14N14-30-2	1360.8	680.4	1178.5	1143.4	3040.4	0.595	0.388
14N10-60-1	1081.3	936.4	540.6	869.0	2650.6	1.078	0.204
14N10-60-2	874.6	757.4	437.3	869.0	2650.6	0.872	0.165
14N14-15-1	1622.3	419.9	1567.1	835.8	1885.2	0.502	0.831
14N14-15-2	1823.3	471.9	1761.1	835.8	1885.2	0.565	0.934
20N08-75-1	199.6	192.8	51.7	199.9	420.4	0.964	0.123
20N10-75-1	243.3	235.0	63.0	231.6	452.5	1.014	0.139
14N08-75-1	718.3	693.8	185.9	750.1	2462.5	0.925	0.075
14N10-75-1	914.7	883.6	236.8	869.0	2650.6	1.017	0.089
14N10-75-2	906.4	875.5	234.6	869.0	2650.6	1.008	0.089

Table B.2 Analyzed Test Data for Low-Ductility Specimens

Specimen No.	P _u (lbf)	P _{ut} (lbf)	P _{uv} (lbf)	P _{not} (lbf)	P _{ns} (lbf)	$\frac{P_{ut}}{P_{not}}$	$\frac{P_{uv}}{P_{ns}}$
20L08-30-1	445.5	222.8	385.8	483.2	1066.1	0.461	0.362
20L08-30-2	437.1	218.5	378.5	483.2	1066.1	0.452	0.355
20L10-30-1	711.3	355.7	616.0	559.8	1147.5	0.635	0.537
20L10-30-2	465.5	232.8	403.1	559.8	1147.5	0.416	0.351
20L12-30-1	525.6	262.8	455.2	636.4	1223.5	0.413	0.372
20L12-30-2	547.3	273.7	474.0	636.4	1223.5	0.430	0.387
20L14-30-1	607.3	303.6	525.9	736.6	1316.3	0.412	0.400
20L14-30-2	612.1	306.0	530.1	736.6	1316.3	0.415	0.403
20L10-60-1	443.0	383.6	221.5	559.8	1147.5	0.685	0.193
20L10-60-2	438.8	380.0	219.4	559.8	1147.5	0.679	0.191
20L14-15-1	668.7	173.1	645.9	844.7	1616.5	0.205	0.400
20L14-15-2	651.6	168.7	629.4	844.7	1616.5	0.200	0.389
18L12-30-1	714.1	357.1	618.5	627.7	1292.4	0.569	0.479
18L12-30-2	736.7	368.4	638.0	627.7	1292.4	0.587	0.494
18L14-30-1	749.0	374.5	648.7	726.6	1390.4	0.515	0.467
18L14-30-2	771.4	385.7	668.0	726.6	1390.4	0.531	0.480
18L10-60-1	598.2	518.1	299.1	552.2	1212.1	0.938	0.247
18L10-60-2	581.5	503.6	290.8	552.2	1212.1	0.912	0.240

Specimen No.	P _u (lbf)	P _{ut} (lbf)	P _{uv} (lbf)	P _{not} (lbf)	P _{ns} (lbf)	$\frac{P_{ut}}{P_{not}}$	$\frac{P_{uv}}{P_{ns}}$
18L14-15-1	911.2	235.8	880.2	726.6	1390.4	0.325	0.633
18L14-15-2	950.0	245.9	917.6	726.6	1390.4	0.338	0.660
16L12-30-1	821.4	410.7	711.3	836.1	2003.5	0.491	0.355
16L12-30-2	778.9	389.4	674.5	836.1	2003.5	0.466	0.337
16L14-30-1	1004.9	502.4	870.3	967.7	2155.5	0.519	0.404
16L14-30-2	919.1	459.6	796.0	967.7	2155.5	0.475	0.369
16L10-60-1	663.4	574.5	331.7	735.5	1879.1	0.781	0.177
16L10-60-2	640.2	554.5	320.1	735.5	1879.1	0.754	0.170
16L14-15-1	1081.5	279.9	1044.6	967.7	2155.5	0.289	0.485
16L14-15-2	1092.0	282.6	1054.8	967.7	2155.5	0.292	0.489
14L14-30-1	1597.4	798.7	1383.4	1729.4	4440.1	0.462	0.312
14L14-30-2	1845.0	922.5	1597.8	1729.4	4440.1	0.533	0.360
14L10-60-1	1159.5	1004.1	579.7	1314.3	3870.8	0.764	0.150
14L10-60-2	1278.4	1107.1	639.2	1314.3	3870.8	0.842	0.165
14L08-75-1	887.8	857.6	229.8	1134.5	3596.2	0.756	0.064
14L08-75-2	940.4	908.3	243.4	1134.5	3596.2	0.801	0.068
14L10-75-1	878.8	848.8	227.4	1314.3	3870.8	0.646	0.059
14L10-75-2	987.4	953.7	255.6	1314.3	3870.8	0.726	0.066

APPENDIX C

TRI-LINEAR EQUATION CORRELATION

C.1 Normal-Ductility Tri-Linear Correlation (L = 1.0)

Specimen No.	$\frac{P_{ut}}{LP_{not}}$	$\frac{P_{uv}}{LP_{ns}}$	$\frac{P_{ut}}{LP_{not}} + \frac{P_{uv}}{LP_{ns}} \leq 1.15$
20N14-15-1	0.261	0.496	0.757
20N14-15-2	0.275	0.523	0.799
18N14-15-1	0.388	0.739	1.127
18N14-15-2	0.404	0.768	1.172
16N14-15-1	0.331	0.548	0.879
16N14-15-2	0.354	0.585	0.939
14N14-30-1	0.477	0.311	0.788
14N14-30-2	0.517	0.337	0.855
14N14-15-1	0.437	0.723	1.160
14N14-15-2	0.491	0.812	1.303
20N08-30-1	0.618	0.509	1.127
20N08-30-2	0.577	0.475	1.051
20N10-30-1	0.559	0.496	1.055
20N10-30-2	0.576	0.510	1.086
20N12-30-1	0.739	0.698	1.437
20N12-30-2	0.643	0.608	1.250
20N14-30-1	0.503	0.512	1.015
20N14-30-2	0.504	0.513	1.017
18N12-30-1	0.635	0.522	1.157
18N12-30-2	0.645	0.529	1.175
18N14-30-1	0.646	0.570	1.216
18N14-30-2	0.645	0.570	1.215

Specimen No.	$\frac{P_{ut}}{LP_{not}}$	$\frac{P_{uv}}{LP_{ns}}$	$\frac{P_{ut}}{LP_{not}} + \frac{P_{uv}}{LP_{ns}} \leq 1.15$
16N12-30-1	0.517	0.369	0.886
16N12-30-2	0.497	0.355	0.851
16N14-30-1	0.448	0.344	0.792
16N14-30-2	0.513	0.394	0.907
20N10-60-1	0.846	0.250	1.095
20N10-60-2	1.098	0.324	1.422
18N10-60-1	0.986	0.253	1.239
18N10-60-2	0.790	0.203	0.992
16N10-60-1	0.616	0.137	0.754
16N10-60-2	0.819	0.183	1.002
14N10-60-1	0.937	0.177	1.114
14N10-60-2	0.758	0.143	0.901
20N08-75-1	0.838	0.107	0.964
20N10-75-1	0.882	0.121	1.014
14N08-75-1	0.804	0.066	0.925
14N10-75-1	0.884	0.078	1.017
14N10-75-2	0.876	0.077	1.008

Mean Value = 1.038
Standard Deviation = 0.174
Coefficient of Variation = 0.167

C.2 Low-Ductility Tri-Linear Correlation (L = 0.75)

Specimen No.	$\frac{P_{ut}}{LP_{not}}$	$\frac{P_{uv}}{LP_{ns}}$	$\frac{P_{ut}}{LP_{not}} + \frac{P_{uv}}{LP_{ns}} \leq 1.15$
20L14-15-1	0.241	0.470	0.954
20L14-15-2	0.235	0.458	0.936
18L14-15-1	0.382	0.745	1.359
18L14-15-2	0.398	0.776	0.889
16L14-15-1	0.340	0.570	0.910
16L14-15-2	0.344	0.576	0.948
20L08-30-1	0.542	0.426	0.941
20L08-30-2	0.532	0.418	0.949
20L10-30-1	0.747	0.632	1.018
20L10-30-2	0.489	0.413	1.009
20L12-30-1	0.486	0.438	0.701
20L12-30-2	0.506	0.456	0.683
20L14-30-1	0.485	0.470	1.214
20L14-30-2	0.489	0.474	1.253
18L12-30-1	0.669	0.563	1.139
18L12-30-2	0.690	0.581	1.172
18L14-30-1	0.606	0.549	1.374
18L14-30-2	0.625	0.565	1.336
16L12-30-1	0.578	0.418	1.110
16L12-30-2	0.548	0.396	1.158
16L14-30-1	0.611	0.475	0.981
16L14-30-2	0.559	0.434	0.930

Specimen No.	$\frac{P_{ut}}{LP_{not}}$	$\frac{P_{uv}}{LP_{ns}}$	$\frac{P_{ut}}{LP_{not}} + \frac{P_{uv}}{LP_{ns}} \leq 1.15$
14L14-30-1	0.543	0.367	0.910
14L14-30-2	0.628	0.423	0.979
20L10-60-1	0.806	0.227	1.110
20L10-60-2	0.799	0.225	1.072
18L10-60-1	1.104	0.290	0.897
18L10-60-2	1.073	0.282	0.906
16L10-60-1	0.919	0.208	0.897
16L10-60-2	0.887	0.200	1.036
14L10-60-1	0.899	0.176	1.019
14L10-60-2	0.991	0.194	1.168
14L08-75-1	0.829	0.070	0.940
14L08-75-2	0.878	0.074	0.995
14L10-75-1	0.708	0.062	0.803
14L10-75-2	0.796	0.070	0.902

Mean Value = 1.021
Standard Deviation = 0.163
Coefficient of Variation = 0.159

APPENDIX D

NONLINEAR EQUATION CORRELATION

D.1 Normal-Ductility Nonlinear Correlation (L = 1.0)

Specimen No.	$\frac{P_{ut}}{LP_{not}}$	$\frac{P_{uv}}{LP_{ns}}$	$\left(\frac{P_{ut}}{LP_{not}}\right)^{1.15} + \left(\frac{P_{uv}}{LP_{ns}}\right)^{1.15} \leq 1.0$
20N14-15-1	0.300	0.571	0.775
20N14-15-2	0.316	0.602	0.824
18N14-15-1	0.447	0.849	1.225
18N14-15-2	0.464	0.883	1.281
16N14-15-1	0.381	0.630	0.918
16N14-15-2	0.407	0.673	0.990
14N14-30-1	0.549	0.357	0.808
14N14-30-2	0.595	0.388	0.887
14N14-15-1	0.502	0.831	1.262
14N14-15-2	0.565	0.934	1.443
20N08-30-1	0.711	0.585	1.215
20N08-30-2	0.663	0.546	1.122
20N10-30-1	0.643	0.570	1.126
20N10-30-2	0.662	0.587	1.164
20N12-30-1	0.849	0.803	1.606
20N12-30-2	0.739	0.699	1.369
20N14-30-1	0.579	0.588	1.077
20N14-30-2	0.580	0.590	1.080
18N12-30-1	0.731	0.600	1.253
18N12-30-2	0.742	0.609	1.275
18N14-30-1	0.743	0.656	1.326
18N14-30-2	0.742	0.655	1.325

Specimen No.	$\frac{P_{ut}}{LP_{not}}$	$\frac{P_{uv}}{LP_{ns}}$	$\left(\frac{P_{ut}}{LP_{not}}\right)^{1.15} + \left(\frac{P_{uv}}{LP_{ns}}\right)^{1.15} \leq 1.0$
16N12-30-2	0.571	0.408	0.882
16N14-30-1	0.515	0.395	0.810
16N14-30-2	0.590	0.453	0.948
20N10-60-1	0.972	0.287	1.207
20N10-60-2	1.262	0.373	1.629
18N10-60-1	1.134	0.291	1.397
18N10-60-2	0.908	0.233	1.083
16N10-60-1	0.709	0.158	0.793
16N10-60-2	0.942	0.210	1.100
14N10-60-1	1.078	0.204	1.250
14N10-60-2	0.872	0.165	0.980
20N08-75-1	0.964	0.123	1.049
20N10-75-1	1.014	0.139	1.120
14N08-75-1	0.925	0.075	0.965
14N10-75-1	1.017	0.089	1.081
14N10-75-2	1.008	0.089	1.070

Mean Value = 1.119
Standard Deviation = 0.215
Coefficient of Variation = 0.192

D.2 Low-Ductility Nonlinear Correlation (L = 0.8)

Specimen No.	$\frac{P_{ut}}{LP_{not}}$	$\frac{P_{uv}}{LP_{ns}}$	$\left(\frac{P_{ut}}{LP_{not}}\right)^{1.15} + \left(\frac{P_{uv}}{LP_{ns}}\right)^{1.15} \leq 1.0$
20L14-15-1	0.256	0.499	0.659
20L14-15-2	0.250	0.487	0.640
18L14-15-1	0.406	0.791	1.118
18L14-15-2	0.423	0.825	1.173
16L14-15-1	0.362	0.606	0.872
16L14-15-2	0.365	0.612	0.882
20L08-30-1	0.576	0.452	0.932
20L08-30-2	0.565	0.444	0.912
20L10-30-1	0.794	0.671	1.399
20L10-30-2	0.520	0.439	0.859
20L12-30-1	0.516	0.465	0.882
20L12-30-2	0.538	0.484	0.924
20L14-30-1	0.515	0.499	0.917
20L14-30-2	0.519	0.503	0.925
18L12-30-1	0.711	0.598	1.229
18L12-30-2	0.734	0.617	1.274
18L14-30-1	0.644	0.583	1.141
18L14-30-2	0.664	0.601	1.180
16L12-30-1	0.614	0.444	0.964
16L12-30-2	0.582	0.421	0.906
16L14-30-1	0.649	0.505	1.064
16L14-30-2	0.594	0.462	0.960

Specimen No.	$\frac{P_{ut}}{LP_{not}}$	$\frac{P_{uv}}{LP_{ns}}$	$\left(\frac{P_{ut}}{LP_{not}}\right)^{1.15} + \left(\frac{P_{uv}}{LP_{ns}}\right)^{1.15} \leq 1.0$
14L14-30-1	0.577	0.389	0.870
14L14-30-2	0.667	0.450	1.026
20L10-60-1	0.857	0.241	1.032
20L10-60-2	0.849	0.239	1.021
18L10-60-1	1.173	0.308	1.460
18L10-60-2	1.140	0.300	1.413
16L10-60-1	0.976	0.221	1.149
16L10-60-2	0.942	0.213	1.103
14L10-60-1	0.955	0.187	1.094
14L10-60-2	1.053	0.206	1.224
14L08-75-1	0.881	0.074	0.915
14L08-75-2	0.933	0.079	0.977
14L10-75-1	0.753	0.066	0.765
14L10-75-2	0.846	0.074	0.875

Mean Value = 1.020
Standard Deviation = 0.192
Coefficient of Variation = 0.189

D.3 Low-Ductility Nonlinear Correlation based on Chapter 5
Recommendations (L = 0.75)

Specimen No.	$\frac{P_{ut}}{LP_{not}}$	$\frac{P_{uv}}{LP_{ns}}$	$\left(\frac{P_{ut}}{LP_{not}}\right)^{1.15} + \left(\frac{P_{uv}}{LP_{ns}}\right)^{1.15} \leq 1.0$
20L14-15-1	0.273	0.533	0.710
20L14-15-2	0.266	0.519	0.689
18L14-15-1	0.433	0.844	1.205
18L14-15-2	0.451	0.880	1.264
16L14-15-1	0.386	0.646	0.940
16L14-15-2	0.389	0.652	0.950
20L08-30-1	0.615	0.483	1.004
20L08-30-2	0.603	0.473	0.982
20L10-30-1	0.847	0.716	1.507
20L10-30-2	0.554	0.468	0.925
20L12-30-1	0.551	0.496	0.950
20L12-30-2	0.573	0.517	0.995
20L14-30-1	0.550	0.533	0.987
20L14-30-2	0.554	0.537	0.996
18L12-30-1	0.758	0.638	1.324
18L12-30-2	0.782	0.658	1.372
18L14-30-1	0.687	0.622	1.229
18L14-30-2	0.708	0.641	1.271
16L12-30-1	0.655	0.473	1.038
16L12-30-2	0.621	0.449	0.976
16L14-30-1	0.692	0.538	1.146
16L14-30-2	0.633	0.492	1.034

Specimen No.	$\frac{P_{ut}}{LP_{not}}$	$\frac{P_{uv}}{LP_{ns}}$	$\left(\frac{P_{ut}}{LP_{not}}\right)^{1.15} + \left(\frac{P_{uv}}{LP_{ns}}\right)^{1.15} \leq 1.0$
14L14-30-1	0.616	0.415	0.937
14L14-30-2	0.711	0.480	1.106
20L10-60-1	0.914	0.257	1.111
20L10-60-2	0.905	0.255	1.099
18L10-60-1	1.251	0.329	1.572
18L10-60-2	1.216	0.320	1.522
16L10-60-1	1.042	0.235	1.237
16L10-60-2	1.005	0.227	1.188
14L10-60-1	1.019	0.200	1.178
14L10-60-2	1.123	0.220	1.318
14L08-75-1	0.940	0.079	0.985
14L08-75-2	0.995	0.084	1.053
14L10-75-1	0.803	0.071	0.824
14L10-75-2	0.902	0.079	0.942

Mean Value = 1.099
Standard Deviation = 0.207
Coefficient of Variation = 0.189

BIBLIOGRAPHY

American Iron and Steel Institute. (1996). *Cold-Formed Steel Design Manual* (1996 ed.). Washington D.C.: AISI.

American Iron and Steel Institute. (2007). *Commentary on North American Specification for the Design of Cold-Formed Steel Structural Members* (2007 ed.). Washington D.C.: AISI.

American Iron and Steel Institute. (2007). *North American Specification for the Design of Cold-Formed Steel Structural Members* (2007 ed.). Washington D.C.: AISI.

American Iron and Steel Institute. (1946). *Specification for the Design of Light Gage Steel Structural Members* (1946 ed.). New York, NY: AISI.

ASTM International. (2007). *Designation: A370-071 Standard Test Methods and Definitions for Mechanical Testing of Steel Products* (2007 ed.). West Conshohocken, PA: ASTM International.

Ellifritt, D. S., & Burnette, R. (1990). Pull-Over Strength of Screws in Simulated Building Tests. *Tenth International Specialty Conference on Cold-Formed Steel Structures* (pp. 589-603). St. Louis: Wei-Wen Yu Center for Cold-Formed Steel Structures.

Luttrell, L. (1999). Metal Construction Association Diaphragm Test Program. *West Virginia University*.

Pekoz, T. (1990). Design of Cold-Formed Steel Screw Connections. *Tenth Specialty Conference on Cold-Formed Steel Structures* (pp. 575-587). St. Louis: Wei-Wen Yu Center for Cold-Formed Steel Structures.

Yu, W.-W. (2000). *Cold-Formed Steel Design* (3rd ed.). New York, NY: John Wiley and Sons Inc.

Zwick, K., & LaBoube, R. A. (2006). *Self-Drilling Screw Connections Subjected to Combined Shear and Tension*. University of Missouri-Rolla, Civil, Architectural, and Environmental Engineering. Rolla: American Iron and Steel Institute.

VITA

Ryan Michael Francka was born to Kenny and Kathy Francka on February 27th, 1985 in Springfield, Missouri. He has two siblings, Jennifer and Bradley Francka. Ryan graduated from Bolivar High School in 2003. He completed his Bachelor of Science in Civil Engineering from Missouri University of Science and Technology in 2008. During his attendance at Missouri S&T, Ryan was actively involved in the Pi Kappa Phi fraternity, the Chi Epsilon Civil Engineering honors fraternity, and the student chapter of the American Concrete Institute. Before beginning graduate school, Ryan married Tanzeena Hossain, daughter of Mohammed and Tahzeeba Hossain. During his graduate studies he received the Chancellors Fellowship and the Wei-Wen Yu Graduate Fellowship. He also held a graduate teaching assistantship and a graduate research assistantship. Ryan received his Master of Science from Missouri S&T in December 2009. He is a registered engineer intern in the State of Missouri and intends to pursue his professional engineering licensure and a career in structural engineering.

